



**T**america  
PRODUCTS, INC.

**V2000-Pro**

1" to 2" SecureBind™ Hot Knife System



**Operating Manual**



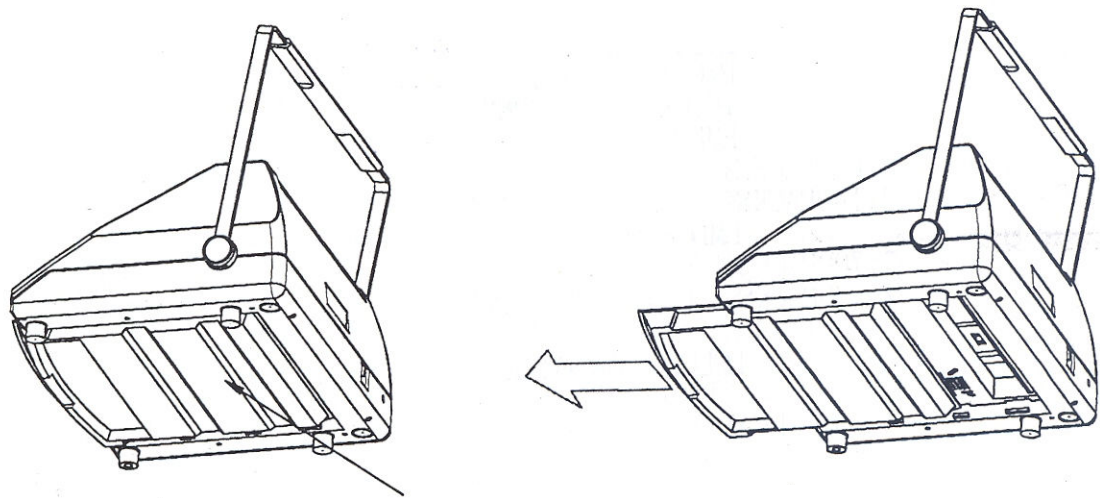
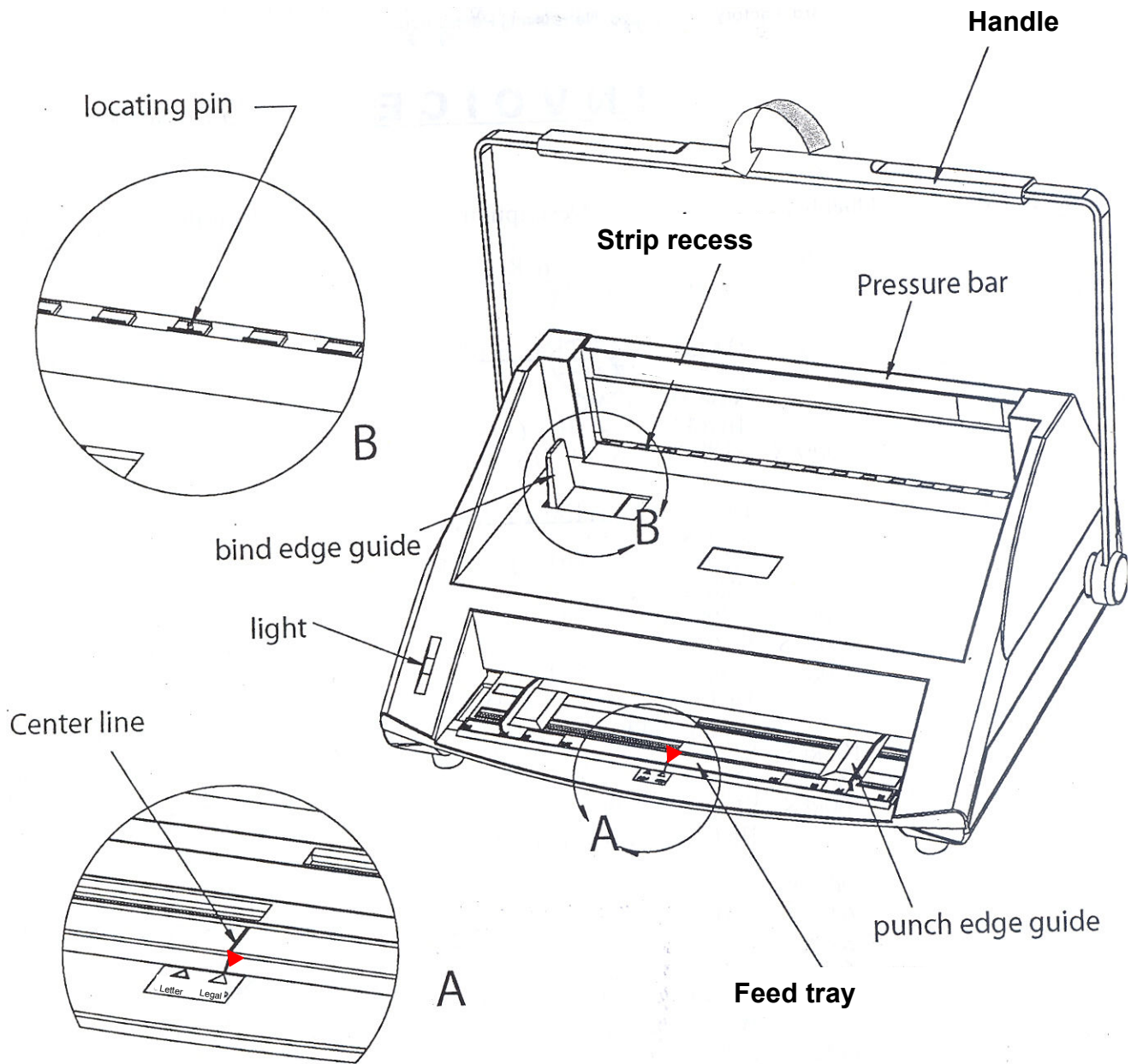

Waste bin

# Punching

2. After adjusting the punch edge guide accordingly, insert the sheets to be punched.

*Note: When punching thicker and rigid materials such as vinyl, composition, pvc and polypropylene covers, punch only (1) sheet at a time.*

1. Raise the handle to starting position Slide the punch edge guide using the red arrow to set it on "Letter" or "Legal".

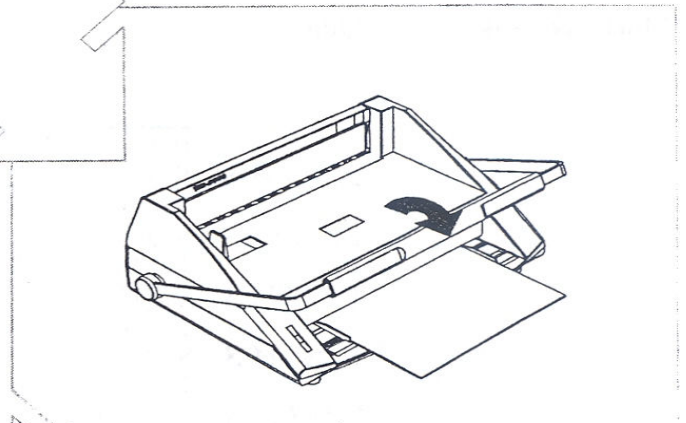
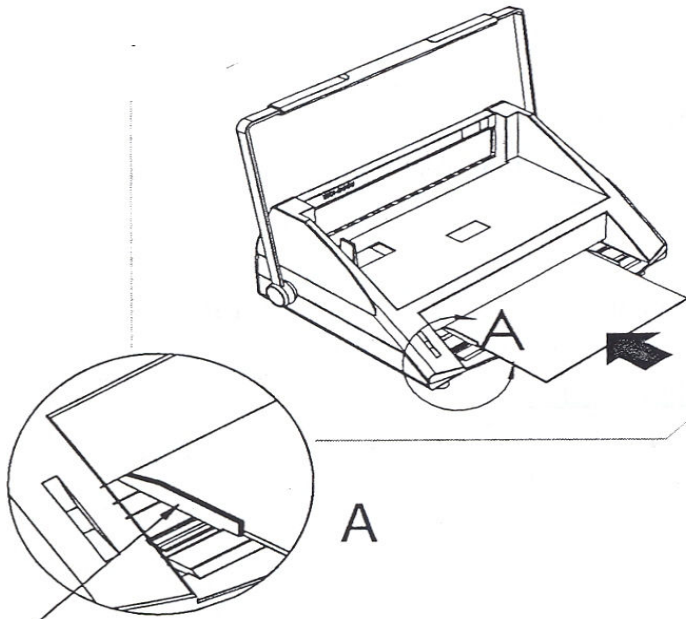
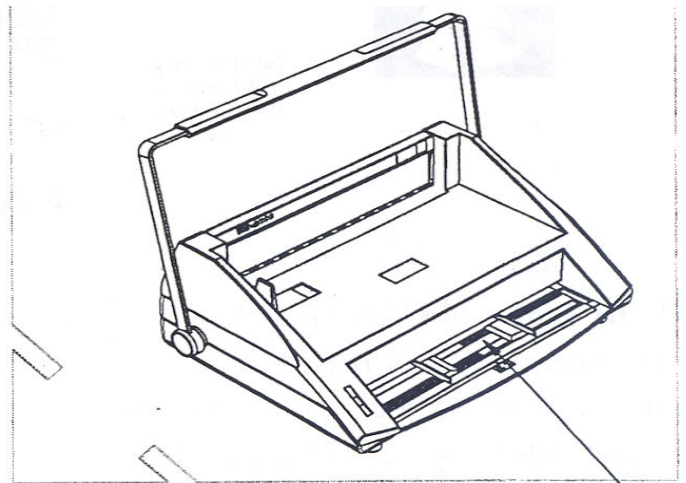

3 Pull the handle to punch the sheets.

4. Raise the handle to remove the sheets.

5. Please make sure to discard punched debris in the waste bin regularly. Punching with a full waste bin will damage the machine.

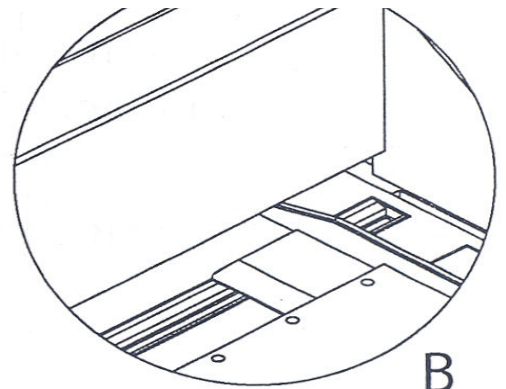
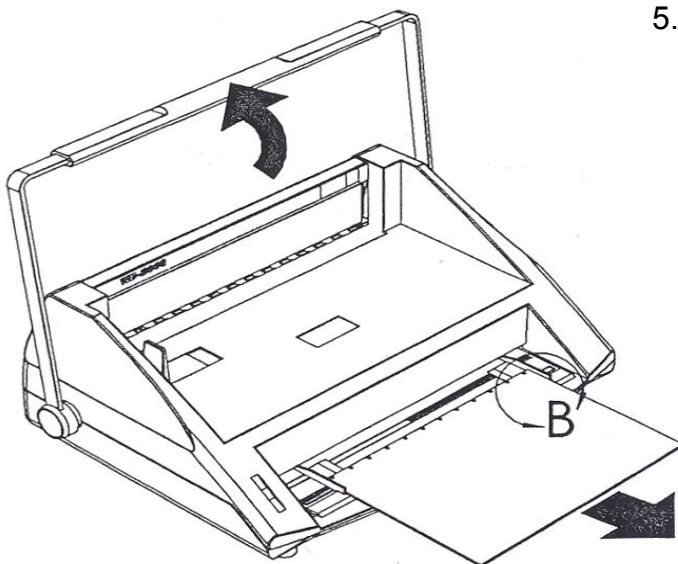

# Document Assembly

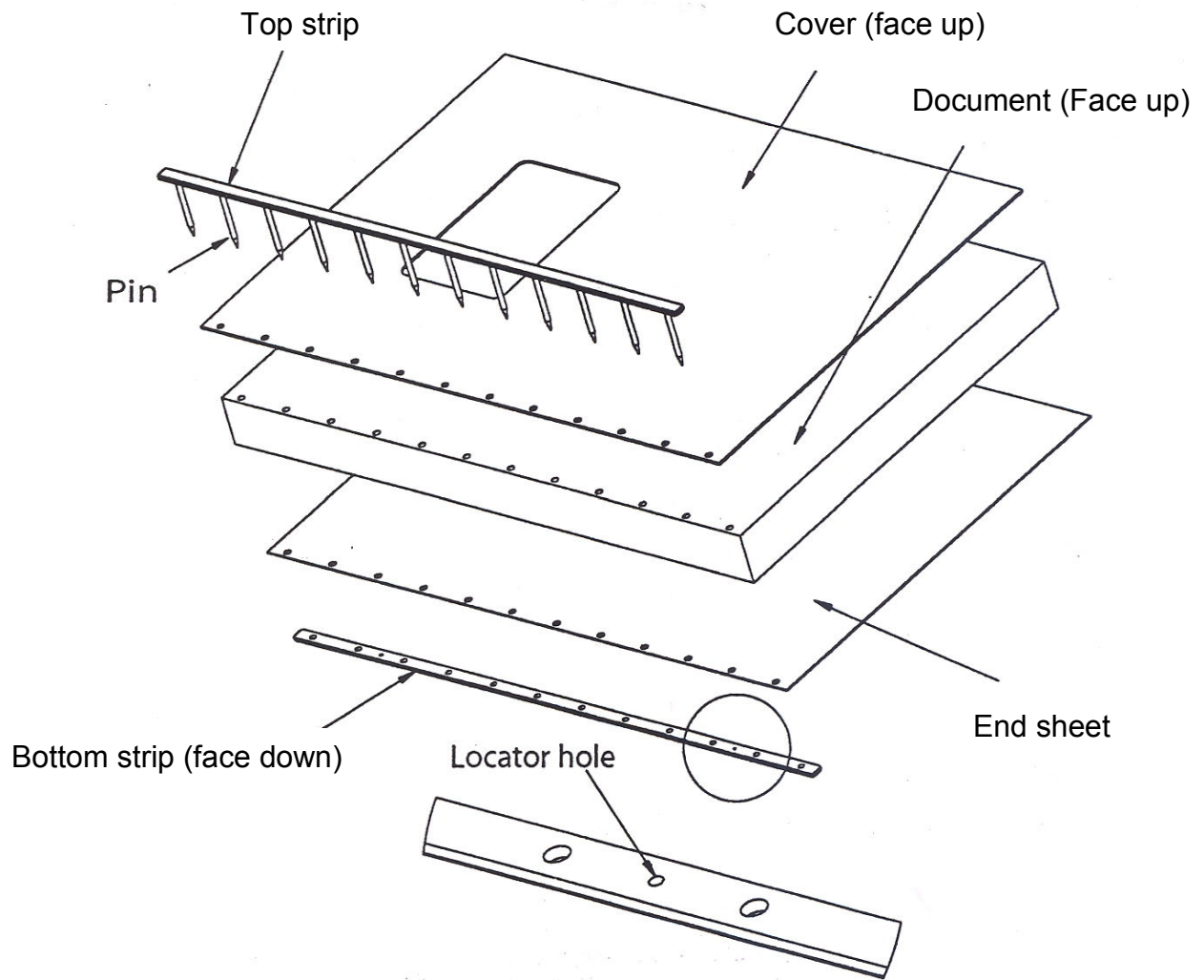

# Feed Tray Adjustment

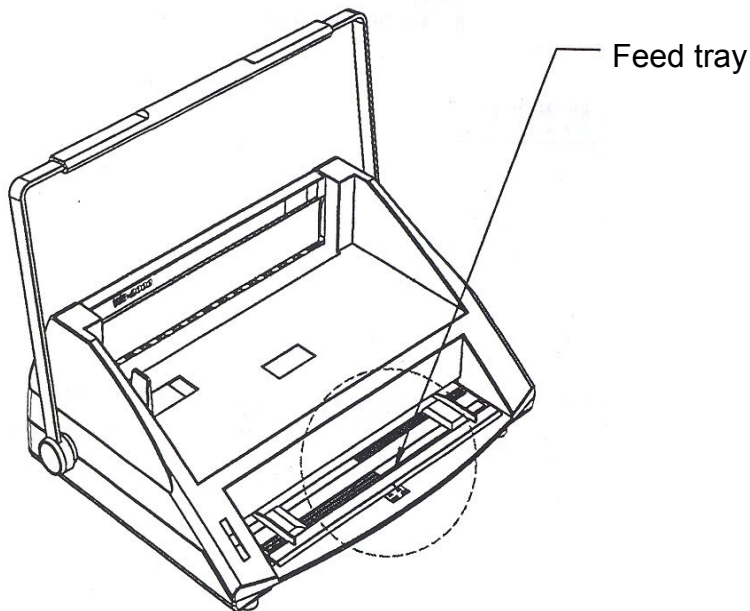

**Maximum Punching Capacity:** 20 sheets of 20 lb paper (75 gsm)

**Maximum Punching/ Binding Length:** 14" (360 mm)

When punching letter size documents, make sure that the center line using the red arrow on the feed tray is on "Letter". When punching legal size documents slide the red arrow to "Legal". The punched holes will not be aligned if this is not followed.

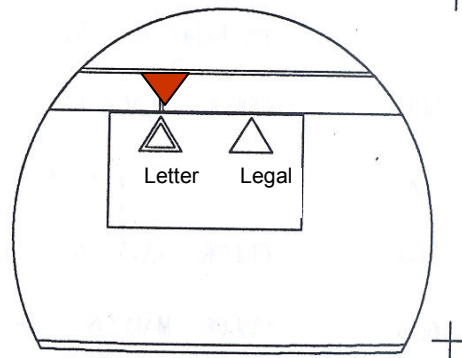

# Binding

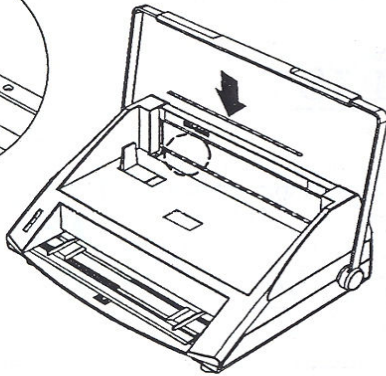
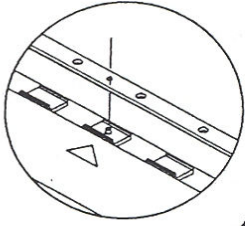

1. Place the bottom strip (textured side faced down) on the strip recess. Make sure that the locator hole is attached to the locating pin. Lay the sheets to be bound on top of the bottom strip. The correct size of top strip is determined by using the scale on the backstop to determine the thickness of the document to be bound.

2. Check if the binding edge guide is aligned – Insert an assembled top and bottom strip with a sheet of aligned & punched paper. Adjust the binding edge guide by sliding the guide to the edge of the paper.

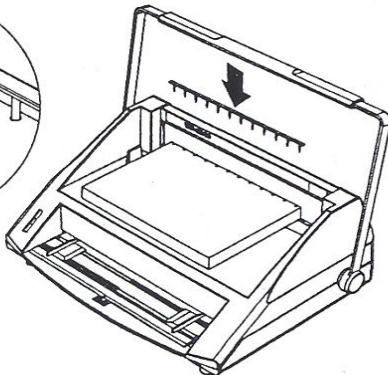
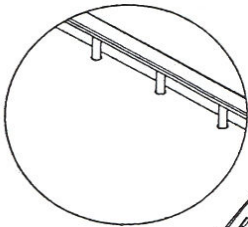
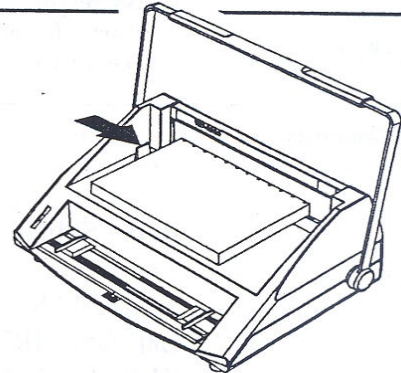

3. Insert the top strip firmly on to the document to be bound.

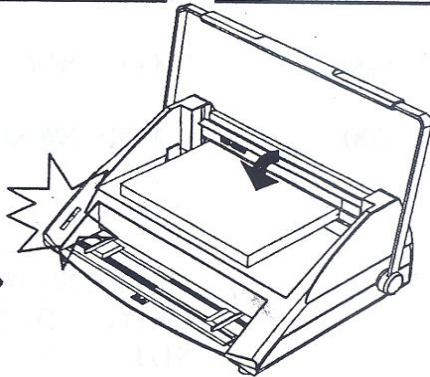

4. Place the pressure bar firmly on the document. The ready light will turn on indicating that the machine is ready for binding.

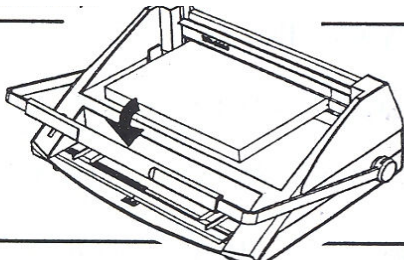

5. Pull the handle all the way down to activate the hot knife strip. It will take about 12-18 seconds to cut all the pins. The indicator light will turn off signifying the completion of the binding job. Lift the handle and pressure bar to return to their resting position then slide the bound document towards yourself to help detach pins that may still be slightly attached to the strip.

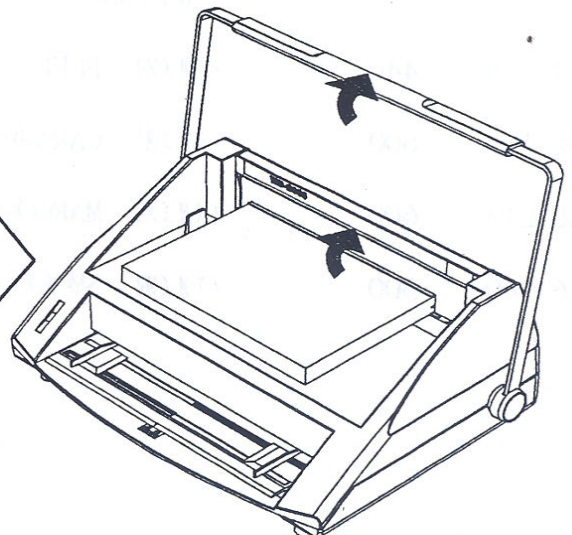

# Specifications

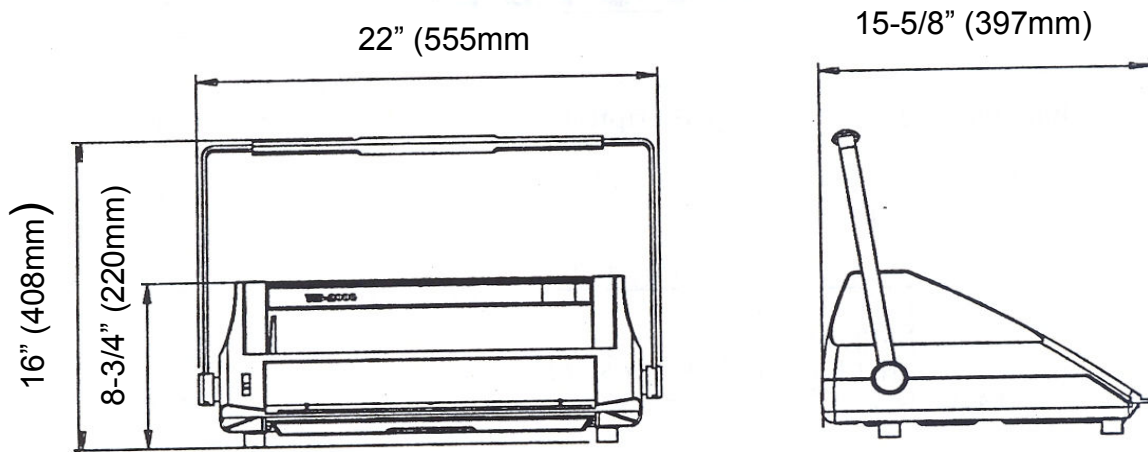

Punching Capacity: 14" (360mm) long X 1/8" (3mm) thick

Binding Capacity: 14" (360mm) long X 2" (50mm) thick

Power Supply: 110V (60Hz) Fuse: 10 amp / 220V (50Hz) Fuse: 5amp

## Machine Dimensions:

Width: 22" (555mm)

Depth: 15-5/8" (397mm)

Height: 8-3/4" (220mm) handle down

16" (408mm) handle up

## Shipping Dimensions:

Width: 23" (580mm)

Depth: 17-5/8" (440mm)

Height: 9-5/8" (245mm)

Weight: 35.2 lbs (16kg)

## **WARRANTY**

This machine is guaranteed against defects in materials and workmanship by the Manufacturer for a period of one (1) year from the date of original purchase from an authorized distributor of Tamerica Products, Inc. If you perceive or experience any issue with the machine, kindly report it to the distributor within 10 business days of said purchase to avail of free pickup and redelivery from Tamerica's Service Center. After the first 10 days, you will either receive service instructions and parts via mail free of charge for the duration of the warranty.

Note that when returning the machine for warranty claims, the machine should be returned in its complete original packaging to avoid incidental or consequential damages that may void the claim. A copy of the invoice or other proof of purchase also needs to be sent with the machine.

Upon evaluation of the machine and the determination of the actual defect, the machine will be restored to its regular working condition by the Service Center and shipped back to you free of charge. If you change your mind and simply want to return the machine, a 20% restocking fee is charged even within the 10-day grace period. Further, you will have to cover freight to return the machine and it has to be in brand-new resalable condition, otherwise, you might incur more charges.

**This warranty covers all defects incurred in the normal use of the equipment except in the following cases:**

1. Loss or damage to the equipment due to improper operation, abuse, mishandling or failure to follow the operating instructions.
2. Removal or alteration of the serial number.
3. The machine being serviced or modified by anyone other than a certified technician authorized by TAMERICA.

This warranty expresses the entire obligation of the Manufacturer. Unless prohibited by law, neither this warranty nor any other warranty expressed or implied, including implied warranties of merchantability, shall extend this warranty period. Again, no responsibility is assured for incidental or consequential damages.

This warranty is valid only within the Contiguous USA, Alaska and Hawaii excluded.